

# THE PARTS LIST OF MODEL

## EB-800-E. 1 (1)

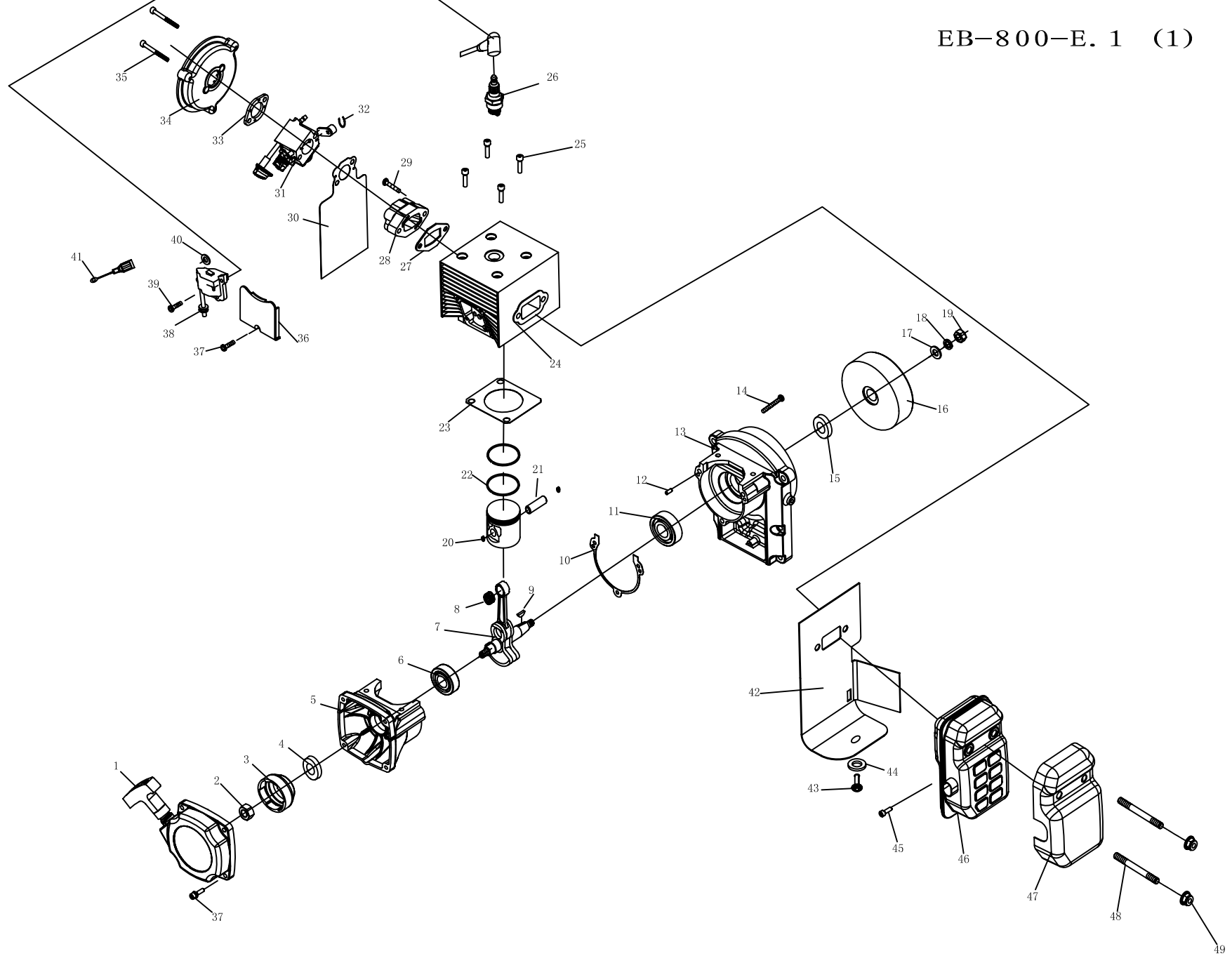

THE PARTS LIST OF MODEL EB-800-E. 1 (2)

NO.	Part No.	Part Name	Qty.	NO.	Part No.	Part Name	Qty.	NO.	Part No.	Part Name	Qty.
1	EB-800-E. 1. 7	STARTER	1	28	EB-800-E. 1. 2	ADMITTING PIPE	1				
2	GB/T6171	NUT M10 × 1	1	29	GB70+GB93+GB97	SCREW M5 × 30	2				
3	EB-800-E. 1-5	START REEL	1	30	EB-800-E. 1-1A	GASKET	1				
4	1E40FP-3Z-11	OIL-SEAL	1	31	EB-800-E. 1. 1	CARBURETOR	1				
5	1E54FP. 2-2	BACK CRANKCASE	1	32	GB894	RING 8	1				
6	GB/T276	BEARING 6202/P5	1	33	EB-800-E. 1-1	Gasket	1				
7	EB-800-E. 1. 5. 1	CRANKSHAFT	1	34	EB-800-E. 2-7	CLEANER INSIDE COVER	1				
8	6MF-30. 1. 4-3	BEARING	1	35	GB70+GB93+GB97	Screw M5 × 55	2				
9	GB1099	KEY 3 × 5 × 13	1	36	EB-800-E. 1-3	SHIELD	1				
10	1E54FP. 2-1	GASKET	1	37	GB70+GB93+GB97	SCREW M5 × 16	5				
11	GB/T276	BEARING 6203/P5	1	38	EB-800-E. 1. 9	MAGNETO	1				
12	GB119. 1	PIN 4h8 × 10	1	39	GB9074. 13	SCREW M4 × 20	2				
13	EB-800-E. 1. 4-1	FRONT CRANKCASE	1	40	P40-5	GASKET	2				
14	GB70+GB93+GB848	SCREW M5 × 35	3	41	EB-800-E. 1-6	STOP WIRE	1				
15	1E40FP-3Z-11	OIL-SEAL	1	42	EB-800-E. 1-4A	GASKET	1				
16	1E46FP. 1. 1-	FLYWHEEL	1	43	GB70. 1	Screw M5 × 8	1				
17	GB97	WASHER 10	1	44	GB96	WASHER 5	1				
18	GB93	WASHER 10	1	45	GB70+GB93+GB97	Screw M5 × 12	1				
19	GB6171	NUT M10 × 1	1	46	EB-800-E. 1. 6	MUFFLER	1				
20	1E58FL. 6-5	RING	2	47	EB-800-E. 1. 8	COVER	1				
21	6MF-30. 1. 4-2	PISTON PIN	1	48	1E40F-5-13C	BOLT	2				
22	1E53FP. 4-2	PISTON RING	2	49	GB6187. 1	NUT M8	2				
23	EB-800-E. 1-7	GASKET	1	50							
24	EB-800-E. 1. 3	CYLINDER	1	51							
25	GB70	SCREW M6 × 20	4	52							
26	SPARK PLUG	BPMR7A	1	53							
27	EB-800-E. 1-2	GASKET	1	54							

Appendix List of Attached  
Fig.2(EB-800-E)

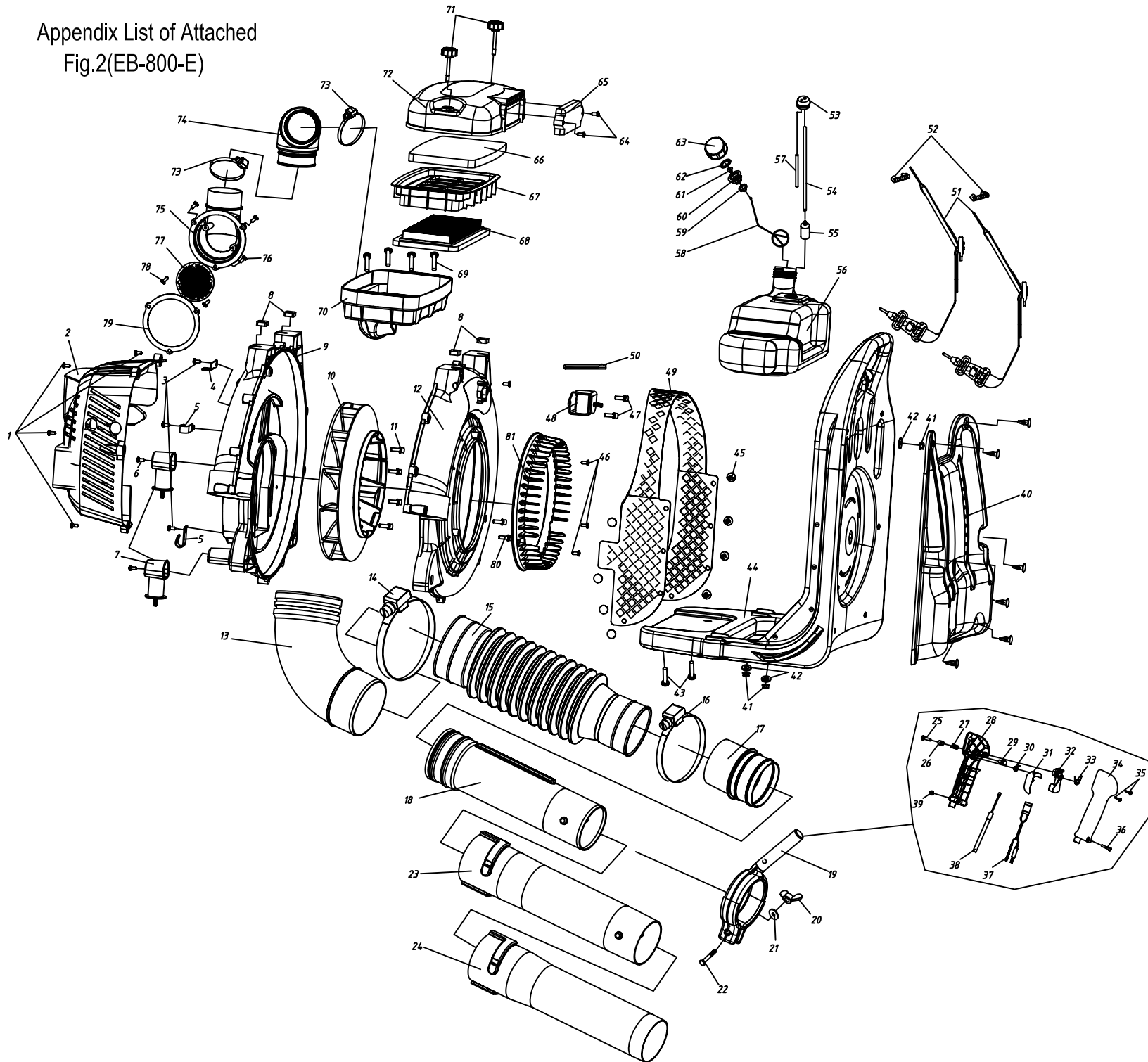

## Appendix List of Attached Fig.2(EB-800-E)

Ser. NO.	Part NO.	Part Name	Qty.	Ser. NO.	Part NO.	Part Name	Qty.	Ser. NO.	Part NO.	Part Name	Qty.
1	3WF-20.9-2	SCREW M5 × 16	4	19	EB-800-E.4.2-1	HANDLE	1	37	BC36.3.1	STOP SWITCH	1
2	EB-800-E-4	PROTECTION	1	20	GB/T62	NUT M5	1	38	EB-800-E.6	FUEL THROTTLE	1
3	3WF-20.9-1	SCREW M5 × 10	3	21	GB/T96.1	WASHER Φ5	1	39	GB/T889.1	NUT M5	1
4	3WF-20A-1	BRACKET	1	22	GB/T5783	BOLT M6 × 45	1	40	EB-800-E-1	BACK MAT	1
5	EB-800-E-5	BRACKET	1	23	EB-800-E.4-2	PIPE	1	41	GB6177	NUT M5	3
6	3WF-20.9-2	SCREW M5 × 16	2	24	EB-800-E.4-3	PIPE	1	42	GB96	WASHER 5	3
7	EB-650.6	SUPPORT	2	25	GB/T846	SCREW ST2.9 × 13	1	43	GB70+GB93+GB848	SCREW M6 × 16	2
8	3WF-3-2	NUT	4	26	BL750.3-9	PUSH BUTTON	1	44	EB-800-E-2	FRAME	1
9	EB-800-E.5.2	FRONT VOLUTE CASE	1	27	BL750.3-7	SPRING	1	45	3WF-2.6B-2	BACK CLIP	14
10	EB-800-E.5.3	IMPELLER	1	28	CG330B-3E.2.1.2	LEFT MANIPULATOR	1	46	3WF-20.9-1	SCREW M5 × 10	3
11	GB70+GB93+GB97	SCREW M5 × 35-10.9	4	29	BL750.3-8	PIN	1	47	GB9074.4	SCREW M5 × 14	2
12	EB-800-E.5.1	BACK VOLUTE CASE	1	30	BL750.3-2	SPRING	1	48	EB-650.8	SUPPORT	1
13	EB-800-E.5-2	PAN JOINT	1	31	BL750.3-3	HANDLE	1	49	EB-800-E-3	PROTECT NET	1
14	JB8870	CLIP Φ90-Φ110	1	32	BL750.3-4	HANDLE	1	50	EB-650.9	PROTECTION	1
15	EB-800-E.4-1	HOSE	1	33	BL750.3-1	LONG SPRING	1	51	EB-650.10(A)(B)-CE	BAND	1
16	Φ78-Φ101	CLIP	1	34	CG330B-3E.2.1-1	RIGHT MANIPULATOR	1	52	EB-650-10	SHAFT	2
17	EB-800-E.4.1-1	JOINT	1	35	GB/T845 ST2.9X18	SCREW	2	53	EB-415.4.2-2	VITTA PLUG	1
18	EB-800-E.4.1-2	PIPE	1	36	GB/T70.1	SCREW M5 × 30	1	54	CG420.1.3.2-2	FUEL TUBE	250mm

70 CLIP

EB-800-E. 2-5	PIPE	1
EB-800-E. 2-6	CLEANER INSIDE COVER	1
XSS46-2. 2-5	SCREW M5 × 20	3
EB-800-E. 2-8	BAFFLE	1
GB845	SCREW ST4. 8 × 9. 5	2
EB-800-E. 2-9	GASKET	1
GB9074. 4	SCREW M5 × 70	2
EB-800-E. 5-1	LEADING WIND COVER	1